



# WLL80P-1IU2Y1DMZZZZ1Z1

## WLL80

FIBER-OPTIC SENSORS

**SICK**  
Sensor Intelligence.



### Ordering information

Type	part no.
WLL80P-1IU2Y1DMZZZ1Z1	6076717

**Included in delivery:** BEF-WLL180 (1)

Other models and accessories → [www.sick.com/WLL80](http://www.sick.com/WLL80)

Illustration may differ



### Detailed technical data

#### Features

<b>Device type</b>	Fiber-optic amplifier	
<b>Device type detail</b>	Base unit <sup>1)</sup>	
<b>Functional principle detail</b>	Depending on the optical fiber cable used	
<b>Sensing range max.</b>	Depending on the optical fiber cable used	
<b>Emitted beam</b>	Light source	LED
	Type of light	Visible red light
<b>Key LED figures</b>	Normative reference	EN 62471:2008-09   IEC 62471:2006, modified
	LED risk group marking	Free group
	Wave length	660 nm
	Average service life	100,000 h at T <sub>a</sub> = +25 °C
<b>Adjustment</b>	Wire/pin	For deactivating the sender and executing the test logic/for setting the sensing range/for resetting the counter
	Display + operating buttons	For configuring the sensor parameters
<b>Display</b>	LED green	Operating indicator Static on: power on
	LED yellow 1	Status of switching output 1 Permanently on: Switching output 1 active Permanently off: Switching output 1 not active Flashing: Executing teach-in/teach-in error
	LED yellow 2	Status of switching output 2 Permanently on: Switching output 2 active Permanently off: Switching output 2 not active Flashing: Executing teach-in/teach-in error
	Display	Display of sensor functions Menu languages: German, English, Chinese, Korean, Japanese
<b>Items supplied</b>	BEF-WLL180 mounting bracket	

<sup>1)</sup> Up to 15 expansion units can be connected.

## Safety-related parameters

<b>MTTF<sub>D</sub></b>	311.4 years
<b>DC<sub>avg</sub></b>	0%
<b>T<sub>M</sub> (mission time)</b>	20 years

## Communication interface

<b>Serial</b>	✓
---------------	---

## Electronics

<b>Supply voltage U<sub>B</sub></b>	12 V DC ... 24 V DC <sup>1)</sup>	
<b>Ripple</b>	± 10 % <sup>2)</sup>	
<b>Current consumption</b>	≤ 50 mA <sup>3)</sup>	
<b>Protection class</b>	III	
<b>Digital output</b>	Number	2 (individually adjustable)
	Type	Push-pull: PNP/NPN <sup>4)</sup>
		PNP
		NPN: open collector
	Switching mode	Light/dark switching
	Signal voltage PNP HIGH/LOW	Approx. U <sub>B</sub> -2.5 V / 0 V
	Signal voltage NPN HIGH/LOW	Approx. U <sub>B</sub> / < 2.5 V
	Output current I <sub>max.</sub>	≤ 100 mA
	Circuit protection outputs	Reverse polarity protected
		Overcurrent protected
		Short-circuit protected
	Response time	≤ 16 μs <sup>5)</sup>
		≤ 70 μs
		≤ 250 μs
		≤ 500 μs
		≤ 1,000 μs
		≤ 2,000 μs
≤ 8,000 μs		
Switching frequency	31.2 kHz <sup>6)</sup>	
	7.1 kHz	
	2 kHz	
	1 kHz	
	500 Hz	
	250 Hz	

<sup>1)</sup> Limit values.

<sup>2)</sup> May not fall below or exceed U<sub>y</sub> tolerances.

<sup>3)</sup> Without load.

<sup>4)</sup> Selectable via menu.

<sup>5)</sup> In bus mode, the fastest response time is 22 μs.

<sup>6)</sup> With a light/dark ratio of 1:1. In bus mode, the highest switching frequency is 22.7 kHz.

	62.5 Hz
Time functions	Switch-on delay, off delay, ON and OFF delay, Impulse (one shot), Switch-on delay and pulse, deactivated
Delay time	Adjustment via operating buttons / via gateway, 0 ms ... 30,000 ms
<b>Digital input</b>	
Number	1
<b>Pin/Wire assignment</b>	
Function of pin 4/black (BK)	Digital output, object present → Output Q1 HIGH
Function of pin 4/black (BK) – detail	The pin 4 function of the sensor can be configured
Function of pin 2/white (WH)	Teach-in input
Function of pin 2/white (WH) – detail	The pin 2 function of the sensor can be configured
Pin 5 function/gray (GY)	Switching output, object present → Q <sub>L2</sub> output HIGH
Pin 5 function/gray (GY) – detail	The pin 5 function of the sensor can be configured

1) Limit values.

2) May not fall below or exceed  $U_V$  tolerances.

3) Without load.

4) Selectable via menu.

5) In bus mode, the fastest response time is 22  $\mu$ s.

6) With a light/dark ratio of 1:1. In bus mode, the highest switching frequency is 22.7 kHz.

### Mechanics

<b>Housing</b>	Rectangular
<b>Dimensions (W x H x D)</b>	10.5 mm x 33.2 mm x 79.9 mm
<b>Connection</b>	Cable, 5-wire, 2 m
<b>Connection detail</b>	
Deep-freeze property	Do not bend below 0 °C
Conductor size	0.18 mm <sup>2</sup>
Cable diameter	Ø 4 mm
Length of cable (L)	2 m
<b>Material</b>	
Housing	Plastic, PC
Protection hood	Plastic, PC
Operating buttons	Plastic, Rubber
Cable	Plastic, PVC
<b>Weight</b>	Approx. 76 g

### Ambient data

<b>Enclosure rating</b>	IP54 (EN 60529)
<b>Ambient operating temperature</b>	-25 °C ... +55 °C <sup>1)</sup>
<b>Ambient temperature, storage</b>	-40 °C ... +70 °C
<b>Typ. Ambient light immunity</b>	Artificial light: ≤ 16,000 lx Sunlight: ≤ 67,000 lx
<b>Shock resistance</b>	50 g, 11 ms (3 positive and 3 negative shocks along X, Y, Z axes, 18 total shocks (EN60068-2-27))

<sup>1)</sup> In bus mode, the temperature range is restricted ( $I_{max}$ : 20 mA): -25 °C ... +45 °C.

<b>Vibration resistance</b>	10 Hz ... 55 Hz (Amplitude 1 mm, 3 x 30 min (EN60068-2-6))
<b>Air humidity</b>	35 % ... 85 %, relative humidity (no condensation)
<b>Electromagnetic compatibility (EMC)</b>	EN 60947-5-2

<sup>1)</sup> In bus mode, the temperature range is restricted ( $I_{max}$  20 mA): -25 °C ... +45 °C.

## Smart Task

<b>Smart Task name</b>	Counter + debouncing
<b>Timer function</b>	Deactivated Switch-on delay Off delay ON and OFF delay Impulse (one shot) Switch-on delay and pulse
<b>Inverter</b>	Yes
<b>Switching signal</b>	
Switching signal Q <sub>L1</sub>	Switching output
Switching signal Q <sub>L2</sub>	Switching output

## Certificates

<b>EU declaration of conformity</b>	✓
<b>UK declaration of conformity</b>	✓
<b>ACMA declaration of conformity</b>	✓
<b>Moroccan declaration of conformity</b>	✓
<b>China-RoHS</b>	✓
<b>cULus certificate</b>	✓
<b>Photobiological safety (DIN EN 62471) certificate</b>	✓
<b>Information according to Art. 3 of Data Act (Regulation EU 2023/2854)</b>	✓

## Classifications

<b>ECLASS 5.0</b>	27270905
<b>ECLASS 5.1.4</b>	27270905
<b>ECLASS 6.0</b>	27270905
<b>ECLASS 6.2</b>	27270905
<b>ECLASS 7.0</b>	27270905
<b>ECLASS 8.0</b>	27270905
<b>ECLASS 8.1</b>	27270905
<b>ECLASS 9.0</b>	27270905
<b>ECLASS 10.0</b>	27270905
<b>ECLASS 11.0</b>	27270905
<b>ECLASS 12.0</b>	27270905
<b>ETIM 5.0</b>	EC002651
<b>ETIM 6.0</b>	EC002651
<b>ETIM 7.0</b>	EC002651
<b>ETIM 8.0</b>	EC002651

UNSPSC 16.0901

39121528

### display and adjustment elements

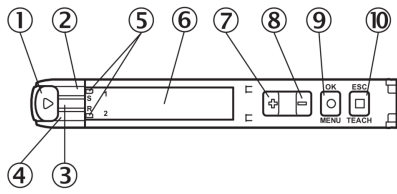

- ① Fiber optic interlock
- ② LED yellow 1
- ③ LED green
- ④ LED yellow 2
- ⑤ Indicator for correctly inserted fibers
- ⑥ Display
- ⑦ (+) button
- ⑧ (-) pushbutton
- ⑨ Menu/OK pushbutton
- ⑩ Teach-in/escape pushbutton

### Connection type Cable, 5-wire

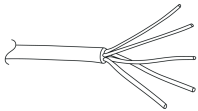

### Connection diagram Cd-532

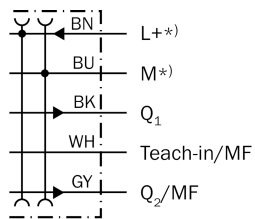

\*) Only base unit

Dimensional drawing

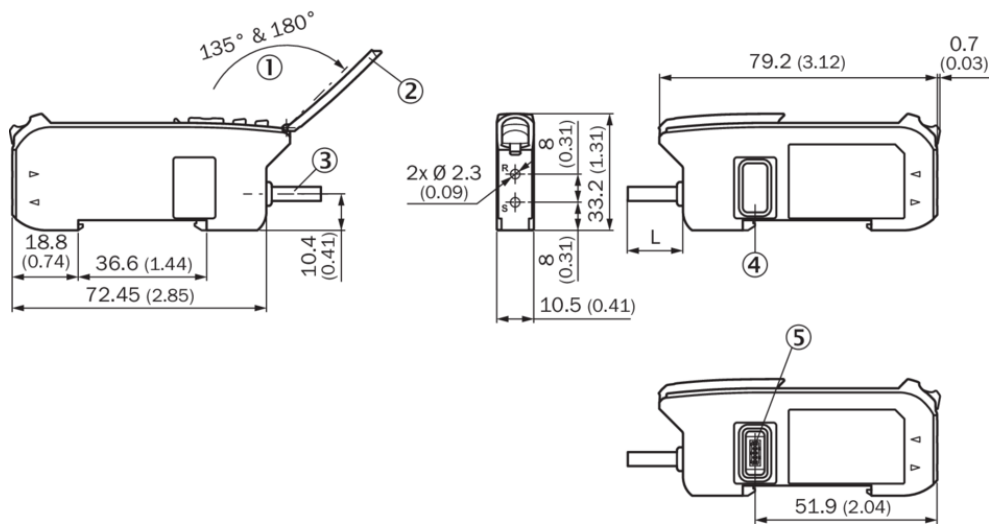





Dimensions in mm (inch)

- ① aperture angle
- ② Hinged cover for the pushbuttons
- ③ Connection
- ④ side cover
- ⑤ Female connector for bus module

### Recommended accessories

Other models and accessories → [www.sick.com/WLL80](http://www.sick.com/WLL80)

	Brief description	Type	part no.
integration modules and adapters			
	<ul style="list-style-type: none"> <li><b>Description:</b> EtherCAT coupler for WLL180T, KTL180 and AOD1. Features: EtherCAT; transmission rates of up to 100 Mbaud; M12 EtherCAT connection; M8 voltage supply connection, 4-pin; full read/write functionality for the process and service data of the connected sensors. See operating instructions for additional information and technical details</li> </ul>	WI180C-EC	6068089
	<ul style="list-style-type: none"> <li><b>Description:</b> IO-Link Smart Sensor Gateway for WLL180T, KTL180 and AOD1; Features: IO-Link; COM3; M8 connection, 4-pin; full read/write functionality for the process and service data of the connected sensors. See operating instructions for additional information and technical details</li> </ul>	WI180C-IOA00	6071650
	<ul style="list-style-type: none"> <li><b>Description:</b> PROFINET coupler for WLL180T, KTL180 and AOD1. Features: PROFINET IRT; transmission rates 10 Mbaud – 100 Mbaud; M12 PROFINET connection; M8 voltage supply connection, 4-pin; full read/write functionality for the process and service data of the connected sensors. See operating instructions for additional information and technical details</li> </ul>	WI180C-PN	6068088
fiber-optic sensors			
	<ul style="list-style-type: none"> <li><b>For fiber optic amplifiers:</b> GLL70, WLL80, WLL180, GLL170(T)</li> <li><b>Functional principle:</b> Proximity system</li> <li><b>Fiber length:</b> 2,000 mm</li> <li><b>Thread diameter (housing):</b> M3</li> <li><b>Fiber material:</b> Plastic</li> <li><b>Jacket material:</b> Plastic</li> <li><b>Fiber head material:</b> Stainless steel</li> <li><b>Included with delivery:</b> Mounting, 2 x M3 hexagon nut, 2 x washer, adapter sleeves, BF-WLL160-13 (1.3 mm) adapter sleeves, FC fiber cutter (5304141)</li> </ul>	LL3-DT01	5308076

## SICK AT A GLANCE

SICK is one of the leading manufacturers of intelligent sensors and sensor solutions for industrial applications. A unique range of products and services creates the perfect basis for controlling processes securely and efficiently, protecting individuals from accidents and preventing damage to the environment.

We have extensive experience in a wide range of industries and understand their processes and requirements. With intelligent sensors, we can deliver exactly what our customers need. In application centers in Europe, Asia and North America, system solutions are tested and optimized in accordance with customer specifications. All this makes us a reliable supplier and development partner.

Comprehensive services complete our offering: SICK LifeTime Services provide support throughout the machine life cycle and ensure safety and productivity.

For us, that is “Sensor Intelligence.”

## WORLDWIDE PRESENCE:

Contacts and other locations –[www.sick.com](http://www.sick.com)