



# EES37-0KF0B015A

EES/EEM37

MOTOR FEEDBACK SYSTEMS

**SICK**  
Sensor Intelligence.

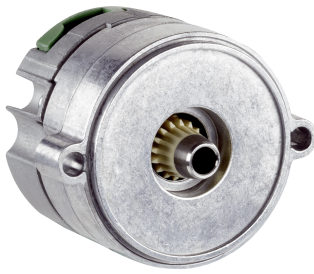

Illustration may differ



### Ordering information

| Type            | part no. |
|-----------------|----------|
| EES37-0KF0B015A | 1086281  |

Other models and accessories → [www.sick.com/EES\\_EEM37](http://www.sick.com/EES_EEM37)

### Detailed technical data

#### Features

|                       |  |
|-----------------------|--|
| <b>Items supplied</b> | M3 mounting screws for encoder housing not included with delivery. |
|-----------------------|--|

#### Safety-related parameters

|  |  |
|--|--|
| <b>MTTF<sub>D</sub> (mean time to dangerous failure)</b> | 170 years (EN ISO 13849) <sup>1)</sup> |
|--|--|

<sup>1)</sup> This product is a standard product and does not constitute a safety component as defined in the Machinery Directive. Calculation based on nominal load of components, average ambient temperature 60 °C, frequency of use 8760 h/a. All electronic failures are considered hazardous. For more information, see document no. 8015532.

#### Performance

| Position   |  |
|--|--|
| Resolution per revolution                        | 15 bit   |
| System accuracy                                  | ± 280 " , nominal position, 25 °C, filter setting 21 kHz <sup>1)</sup> |
|  | ± 190 " , Nominal position, 25 °C, filter setting 1 kHz <sup>1)</sup>  |
| Signal noise (σ)                                 | ± 20 " (nominal position, 25 °C, filter setting 21 kHz)                |
| Number of the absolute ascertainable revolutions | 1  |
| Available memory area                            | 8,192 Byte   |
| Measurement step per revolution                  | 32,768   |

<sup>1)</sup> See diagram for error limits (default filter setting: 21 kHz).

#### Interfaces

|  |   |
|--|---|
| <b>Code sequence</b>                               | Increasing, when turning the shaft For clockwise rotation, looking in direction "A" (see dimensional drawing) |
| <b>Communication interface</b>                     | HIPERFACE DSL <sup>®</sup>  |
| <b>Initialization time</b>                         | Max. 500 ms <sup>1)</sup>   |
| <b>Measurement external temperature resistance</b> | 32-bit value, without prefix (1 Ω) 0 ... 209.600 Ω <sup>2)</sup>  |

<sup>1)</sup> From reaching a permitted operating voltage.

<sup>2)</sup> Without sensor tolerance; at -17 °C ... +167 °C: NTC +2K (103 GT); PTC+3K (KTY84/130/PT1000).

## Electronics

|                                  |                           |
|----------------------------------|---------------------------|
| <b>Connection type</b>           | Male connector, 4-pin     |
| <b>Supply voltage</b>            | 7 V ... 12 V              |
| <b>Warm-up time voltage ramp</b> | Max. 180 ms <sup>1)</sup> |
| <b>Current consumption</b>       | ≤ 150 mA <sup>2)</sup>    |

<sup>1)</sup> Duration of the voltage ramp between 0 and 7.0 V, see diagram "Current consumption" in the diagram section.

<sup>2)</sup> Current rating applies when using interface circuit suggestions as shown in HIPERFACE DSL ® manual (8017595).

## Mechanics

|  |                              |
|--|------------------------------|
| <b>Shaft version</b>                     | Tapered shaft                |
| <b>Dimensions</b>                        | See dimensional drawing      |
| <b>Centering collar</b>                  | Reduced 0.7 mm               |
| <b>Weight</b>                            | ≤ 0.1 kg                     |
| <b>Moment of inertia of the rotor</b>    | 1 gcm <sup>2</sup>           |
| <b>Operating speed</b>                   | ≤ 12,000 min <sup>-1</sup>   |
| <b>Angular acceleration</b>              | ≤ 500,000 rad/s <sup>2</sup> |
| <b>Permissible radial shaft movement</b> | ± 0.15 mm                    |
| <b>Permissible axial shaft movement</b>  | ± 0.5 mm                     |

## Ambient data

|  |   |
|--|---|
| <b>Operating temperature range</b>                 | -40 °C ... +115 °C <sup>1)</sup>  |
| <b>Storage temperature range</b>                   | -40 °C ... +120 °C, without package   |
| <b>Relative humidity/condensation</b>              | 85 %, Condensation not permitted  |
| <b>Resistance to shocks</b>                        | 100 g, 6 ms (according to EN 60068-2-27)  |
| <b>Frequency range of resistance to vibrations</b> | 50 g, 10 Hz ... 2,000 Hz (EN 60068-2-6)   |
| <b>EMC</b>   | According to EN 61000-6-2: 2016, EN 61000-6-4: 2006, IEC 6100-6-7: 2014 <sup>2)</sup>   |
| <b>Enclosure rating</b>                            | IP30, When cover is closed and mating connector is attached (IEC 60529-1) <sup>3)</sup> |

<sup>1)</sup> For typical values for self-heating, see diagram "Electrical self-heating" in the diagram section. see section "Mounting" in the operating instructions (8021414/8021265).

<sup>2)</sup> According to the listed standards, EMC is guaranteed if the motor feedback system with mating plug inserted is connected to the central grounding point of the motor controller via a cable shield. If other shielding concepts are used, users must perform their own tests. Class A device.

<sup>3)</sup> When using the strands (2079920).

## Certificates

|  |   |
|--|---|
| <b>EU declaration of conformity</b>  | ✓ |
| <b>UK declaration of conformity</b>  | ✓ |
| <b>ACMA declaration of conformity</b>  | ✓ |
| <b>China RoHS</b>  | ✓ |
| <b>Information according to Art. 3 of Data Act (Regulation EU 2023/2854)</b> | ✓ |

## Classifications

|                     |          |
|---------------------|----------|
| <b>ECLASS 5.0</b>   | 27270590 |
| <b>ECLASS 5.1.4</b> | 27270590 |
| <b>ECLASS 6.0</b>   | 27270590 |

|                       |          |
|-----------------------|----------|
| <b>ECLASS 6.2</b>     | 27270590 |
| <b>ECLASS 7.0</b>     | 27270590 |
| <b>ECLASS 8.0</b>     | 27270590 |
| <b>ECLASS 8.1</b>     | 27270590 |
| <b>ECLASS 9.0</b>     | 27270590 |
| <b>ECLASS 10.0</b>    | 27273805 |
| <b>ECLASS 11.0</b>    | 27273901 |
| <b>ECLASS 12.0</b>    | 27273901 |
| <b>ETIM 5.0</b>       | EC001486 |
| <b>ETIM 6.0</b>       | EC001486 |
| <b>ETIM 7.0</b>       | EC001486 |
| <b>ETIM 8.0</b>       | EC001486 |
| <b>UNSPSC 16.0901</b> | 41112113 |

### Dimensional drawing

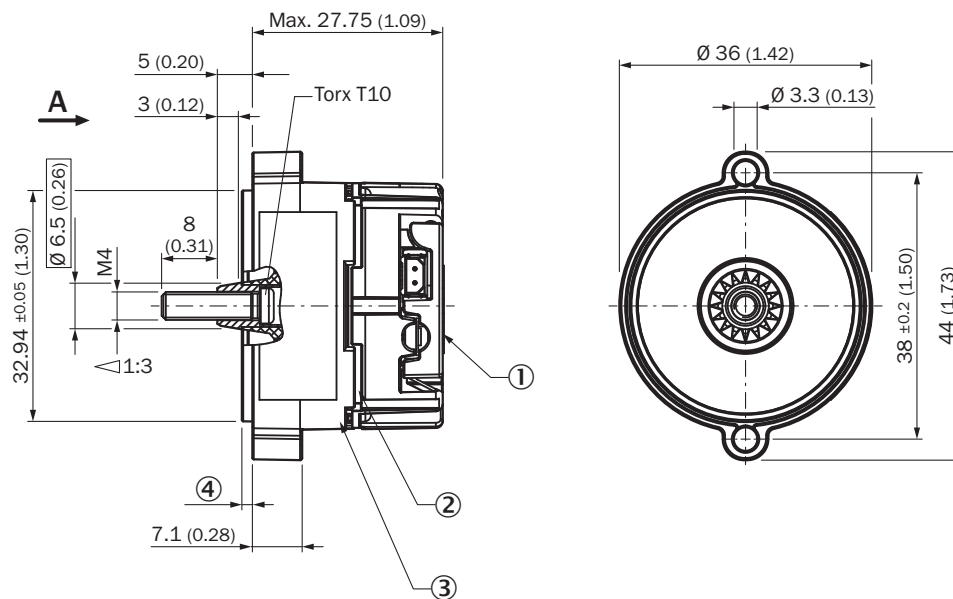

Dimensions in mm (inch)

screw M4 not included (see under accessories)

- ① measuring point for vibrations
- ② Design-related gap
- ③ Measuring point for operating temperature
- ④ Centering collar: Standard 1.5 mm; reduced 0.7 mm

Attachment specifications

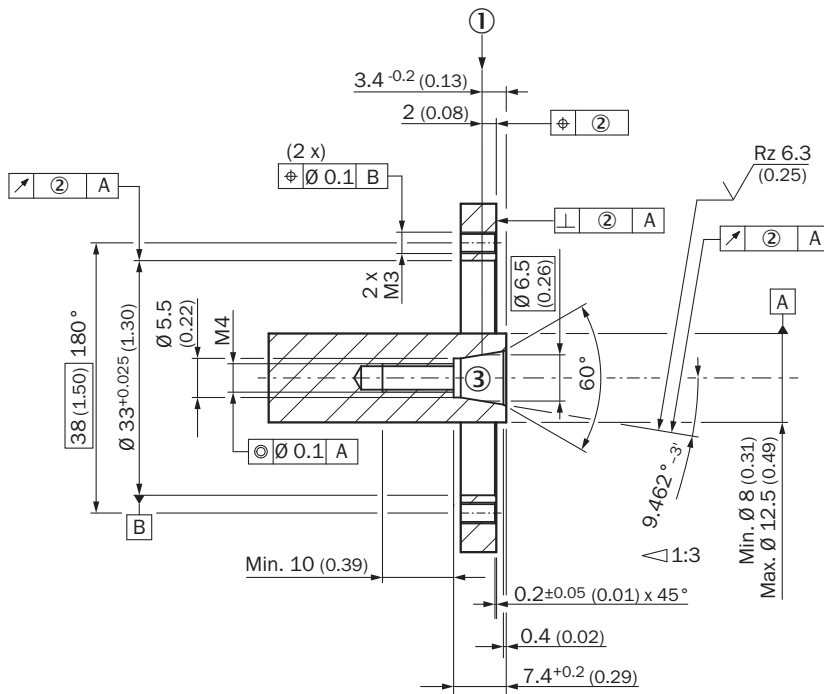

read out axial position: positive value shows movement of rotor away from the motor flange; negative value shows movement of rotor towards the motor flange

- ① Nominal position
- ② The size of the tolerance reduces the permissible wave movement, see data sheet
- ③ Threaded holes in accordance with DIN 13 with recesses in accordance with DIN 76 min. 1.05 x thread diameter

PIN assignment Supply/Communication pin assignment

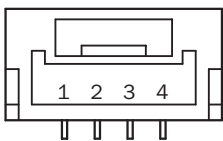

integrated in motor cable = J, K

| PIN | Signal                | Explanation                 |
|-----|-----------------------|-----------------------------|
| 1   | -                     | Not connected - no function |
| 2   | +U <sub>S</sub> /DSL+ | Supply 7 V ... 12 V         |
| 3   | GND/DSL-              | Ground connection           |
| 4   | -                     | Not connected - no function |

Recommended outer diameter of set of stranded wires: 4 mm +0/-1.5 mm

Recommended mating connector: JST (GHR-04V-S)

PIN assignment Temperature sensor pin assignment

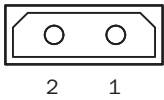

| PIN  | Signal | Explanation                       |
|--|--------|-----------------------------------|
| 1  | T+     | Thermistor connection             |
| 2  | T-     | Thermistor connection (to ground) |
| Recommended outer diameter of set of stranded wires: 2.2 mm ± 0.1 mm |        |                                   |
| Recommended mating connector: Harwin M80-8990205                     |        |                                   |

Diagrams Latency vs. filter frequency

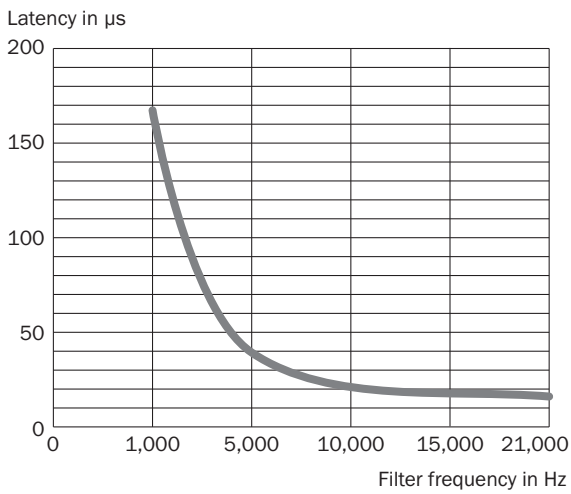

adjustable filter frequencies 21 kHz, 15 kHz, 10 kHz, 5 kHz und 1 kHz - Default setting 21 kHz

### Diagrams Power consumption

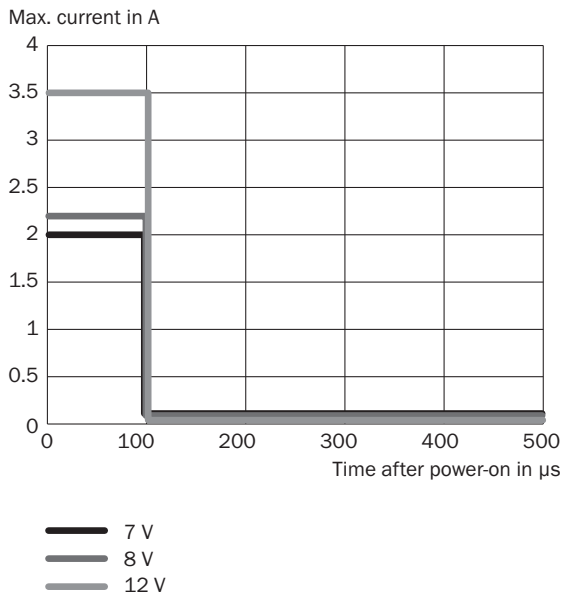

This diagram shows the switch-on current

### Diagrams Electrical self-heating

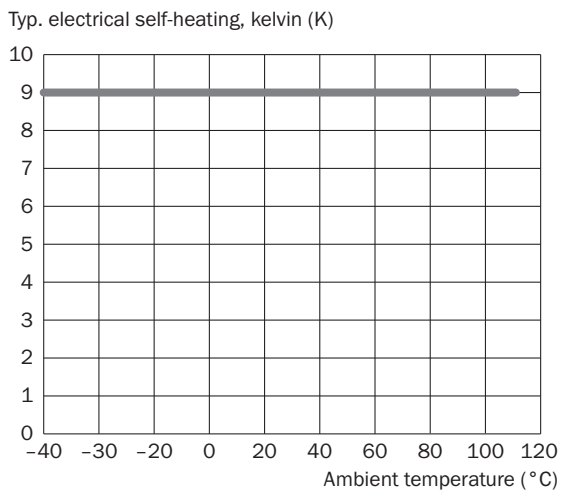

### Diagrams Error limits

Typ. effect of temperature on accuracy, normed

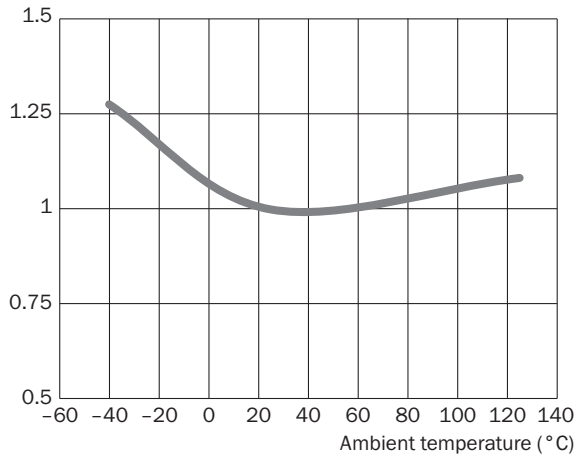

### Diagrams Error limits

Typ. effect of axial position on accuracy, normed

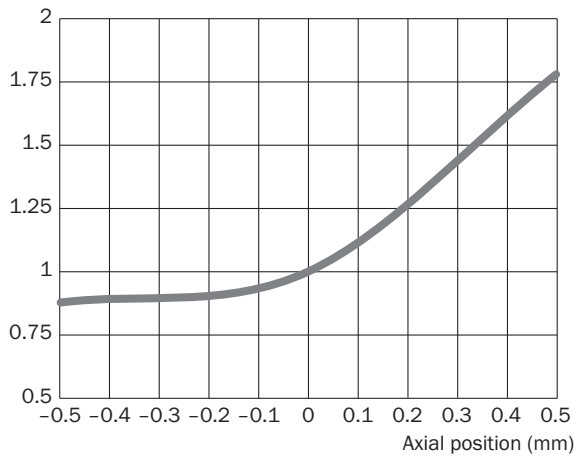

## Operation note Supported resources for HIPERFACE DSL®

| RID   | Name     | time overrun [ms] | Description  |
|-------|----------|-------------------|--|
| 0x000 | ROOT     | 75                | Top node of resource tree (all nodes reachable from here)  |
| 0x001 | IDENT    | 75                | Node with pointers to all identification resources   |
| 0x002 | MONITOR  | 75                | Node with pointers to all monitoring resources   |
| 0x003 | ADMIN    | 75                | Node with pointers to all administration resources   |
| 0x004 | COUNTER  | 75                | Node with pointers to all counter resources  |
| 0x005 | DATA     | 75                | Node with pointers to all user file resources  |
| 0x006 | SENSHUB  | 75                | Node with pointers to all SensorHub resources  |
| 0x080 | ENCTYPE  | 70                | Base functionality of encoder  |
| 0x081 | RESOLUTN | 70                | Number of steps per turn   |
| 0x082 | RANGE    | 70                | Number of encoded revolutions  |
| 0x083 | TYPECODE | 70                | Type name of encoder   |
| 0x084 | SERIALNO | 70                | Serial no of encoder   |
| 0x085 | FWREVNO  | 70                | Firmware and hardware revision of encoder  |
| 0x086 | FWDATE   | 70                | Firmware date of encoder   |
| 0x087 | EESIZE   | 70                | Total amount of memory for user files  |
| 0x0c0 | TEMPRNG  | 70                | Min and max allowed ambient temperature of encoder   |
| 0x0c1 | TEMPRTUR | 70                | Actual ambient temperature of encoder  |
| 0x0c4 | SUPRANGE | 70                | Min and max allowed supply voltage of encoder  |
| 0x0c5 | SUPVOLT  | 70                | Actual supply voltage of encoder   |
| 0x0c6 | SPEEDRNG | 70                | Max allowed shaft speed of encoder   |
| 0x0c7 | SPEED    | 70                | Actual shaft speed of encoder  |
| 0x0c8 | ACCRANGE | 70                | Max allowed shaft acceleration of encoder  |
| 0x0cb | LIFETIME | 70                | Operating time and total shaft turns of encoder. For safety variants also remaining mission time is indicated. |
| 0x0cc | ERRORLOG | 70                | Stored error messages of encoder   |
| 0x0cd | HISTOGRM | 70                | Usage history of encoder in histogram form   |
| 0x0d3 | AXPOSRNG | 70                | Min and max allowed axial position of encoder  |
| 0x0d4 | AXIALPOS | 70                | Actual axial position of encoder   |
| 0x100 | RESET    | 240               | Reset or shutdown of encoder   |
| 0x101 | SETPOS   | 100               | Set encoder position to arbitrary preset value. Offset of position can be read back.                           |
| 0x104 | SETACCES | 70                | Set or read back access level  |
| 0x105 | CHNGEKEY | 90                | Change password for access level   |
| 0x107 | UWARNING | 90                | Set or read back user-defined warning boundaries   |
| 0x108 | FACRESET | 255               | Reset user settings of encoder to factory defaults   |
| 0x109 | ENCIDENT | 90                | Set or read back user-defined encoder index (for multi-axis systems)   |
| 0x10a | POSFILT  | 90                | Set or read back position filter settings  |
| 0x120 | READCNT  | 70                | Read user counter value  |
| 0x121 | INCCOUNT | 90                | Increment user counter value   |
| 0x122 | RESETCNT | 110               | Reset user counter value   |
| 0x130 | LOADFILE | 255               | Load user file   |
| 0x131 | RWFILE   | 250               | Read from or write to user file  |
| 0x132 | FILESTAT | 70                | Read status of user file   |
| 0x133 | MAKEFILE | 190               | Create, change or delete user file   |
| 0x134 | DIR      | 130               | Read directory of accessible user files  |
| 0x200 | ACCESSIO | 70                | Access to simple I/Os connected directly to encoder  |
| 0x201 | MANAGEIO | 90                | Manage simple I/Os   |

Operation note Overview of warnings and fault indications



| Error type             | Error register | Error bit | Description   |
|------------------------|----------------|-----------|---|
| Position (incremental) | 40h            | 0         | A Protocol reset was executed   |
|                        | 40h            | 1         | Acceleration overflow, invalid position                                       |
|                        | 40h            | 3         | Drift compensating error  |
|                        | 40h            | 4         | Internal error in plausibility, invalid position                              |
|                        | 40h            | 5         | Internal error in vector length, invalid position                             |
|                        | 40h            | 6         | Internal error in configuration, invalid position                             |
|                        | 40h            | 7         | Cross check error   |
| Position (absolute)    | 41h            | 0         | Error in absolute position in rotation  |
|                        | 41h            | 1         | Error 1 in absolute position in several rotations                             |
|                        | 41h            | 2         | Error 2 in absolute position in several rotations                             |
|                        | 41h            | 3         | Error 3 in absolute position in several rotations                             |
|                        | 41h            | 4         | Position cross check error  |
| Initialization         | 42h            | 0         | Switch-on self-test undertaken (only safety versions)                         |
|                        | 42h            | 1         | Warning safety parameter: error could not be rectified (only safety versions) |
|                        | 42h            | 2         | Warning safety parameter: error could not be rectified (only safety versions) |
|                        | 42h            | 3         | Error calibration data  |
|                        | 42h            | 4         | Internal communications error 1   |
|                        | 42h            | 5         | Internal communications error 2   |
|                        | 42h            | 6         | Internal general error  |
| Test                   | 43h            | 0         | Critical temperature  |
|                        | 43h            | 1         | Critical rotor position   |
|                        | 43h            | 2         | Critical supply voltage   |
|                        | 43h            | 3         | Critical rotation speed   |
|                        | 43h            | 5         | Critical overflow   |
|                        | 43h            | 4         | Internal test error   |
| Access to resources    | 44h            | 0         | Invalid argument given during resource access procedure                       |
|                        | 44h            | 1         | Resource access refused due to incorrect access level                         |
|                        | 44h            | 2         | Internal error during resource access   |
|                        | 44h            | 3         | Error when accessing a user file  |
| User defined Warnings  | 47h            | 0         | User-defined warning 0  |
|                        | 47h            | 1         | User-defined warning 1  |
|                        | 47h            | 2         | User-defined warning 2  |
|                        | 47h            | 3         | User-defined warning 3  |

Operation note Supported access levels

| Access level | User                      | Standard access key |
|--------------|---------------------------|---------------------|
| 0            | Execute (default setting) | 0000 (30 30 30 30h) |
| 1            | Operator                  | 1111 (31 31 31 31h) |
| 2            | Maintenance               | 2222 (32 32 32 32h) |
| 3            | Authorized client         | 3333 (33 33 33 33h) |
| 4            | User service              | 4444 (34 34 34 34h) |

Recommended accessories

Other models and accessories → [www.sick.com/EES\\_EEM37](http://www.sick.com/EES_EEM37)

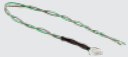
|   | Brief description   | Type             | part no. |
|---|---|------------------|----------|
| Mounting systems  |   |                  |          |
|    | <ul style="list-style-type: none"> <li><b>Description:</b> Screws with Precote 85-8 coating; M4*14</li> <li><b>Packing unit:</b> 100 pieces</li> </ul>  | BEF-MK-S03       | 2077358  |
|    | <ul style="list-style-type: none"> <li><b>Description:</b> Screws with Precote 85-8 coating; M4*14</li> <li><b>Packing unit:</b> 10 pieces</li> </ul>   | BEF-MK-S07       | 2088239  |
|   | <ul style="list-style-type: none"> <li><b>Description:</b> Screws with Precote 85-8 coating; M4*14</li> <li><b>Packing unit:</b> 500 pieces</li> </ul>  | BEF-MK-S08       | 2088240  |
|   | <ul style="list-style-type: none"> <li><b>Description:</b> Test gauge for SEK/SEL34, SEK/SEL37, and EES/EEM37</li> </ul>  | BEF-MW-PL        | 2084768  |
| connectors and cables   |   |                  |          |
|  | <ul style="list-style-type: none"> <li><b>Connection type head A:</b> Female connector, stranded wire, 4-pin, straight</li> <li><b>Connection type head B:</b> Flying leads</li> <li><b>Signal type:</b> HIPERFACE DSL<sup>®</sup></li> <li><b>Cable:</b> 0.2 m, 2-wire</li> <li><b>Description:</b> HIPERFACE DSL<sup>®</sup>, unshielded</li> </ul> | DOL-0B02-G0M2XC2 | 2079920  |

## SICK AT A GLANCE

SICK is one of the leading manufacturers of intelligent sensors and sensor solutions for industrial applications. A unique range of products and services creates the perfect basis for controlling processes securely and efficiently, protecting individuals from accidents and preventing damage to the environment.

We have extensive experience in a wide range of industries and understand their processes and requirements. With intelligent sensors, we can deliver exactly what our customers need. In application centers in Europe, Asia and North America, system solutions are tested and optimized in accordance with customer specifications. All this makes us a reliable supplier and development partner.

Comprehensive services complete our offering: SICK LifeTime Services provide support throughout the machine life cycle and ensure safety and productivity.

For us, that is “Sensor Intelligence.”

## WORLDWIDE PRESENCE:

Contacts and other locations –[www.sick.com](http://www.sick.com)