

# SEM90-HN050AK22

SES/SEM

MOTOR FEEDBACK SYSTEMS

**SICK**  
Sensor Intelligence.

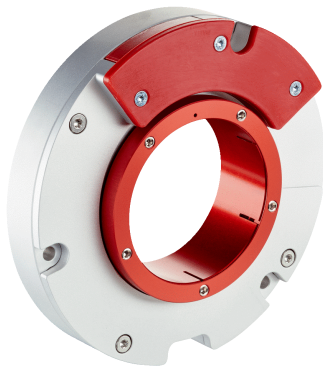

### Ordering information

Type	part no.
SEM90-HN050AK22	1075348

Other models and accessories → [www.sick.com/SES\\_SEM](http://www.sick.com/SES_SEM)

Illustration may differ



### Detailed technical data

#### Features

<b>Items supplied</b>	M3 mounting screws for encoder housing not included with delivery.
-----------------------	--

#### Safety-related parameters

<b>MTTF<sub>D</sub> (mean time to dangerous failure)</b>	160 years (EN ISO 13849) <sup>1)</sup>
--	--

<sup>1)</sup> This product is a standard product and does not constitute a safety component as defined in the Machinery Directive. Calculation based on nominal load of components, average ambient temperature 60 °C, frequency of use 8760 h/a. All electronic failures are considered hazardous. For more information, see document no. 8015532.

#### Performance

<b>Sine/cosine periods per revolution</b>	64
<b>Number of the absolute ascertainable revolutions</b>	4,096
<b>Total number of steps</b>	8,388,608
<b>Measuring step</b>	5 " For interpolation of the sine/cosine signals with, e. g., 12 bits
<b>Integral non-linearity</b>	± 72 " <sup>1)</sup>
<b>Differential non-linearity</b>	± 45 " <sup>1)</sup>
<b>Latency</b>	25 µs
<b>Available memory area</b>	2,048 Byte
<b>System accuracy</b>	± 117 "

<sup>1)</sup> Typical values at nominal position ± 0.1 mm und +20 °C.

#### Interfaces

<b>Type of code for the absolute value</b>	Binary
<b>Code sequence</b>	Rising, For clockwise shaft rotation, looking in direction "A" (see dimensional drawing)
<b>Communication interface</b>	HIPERFACE®

## Electronics

<b>Connection type</b>	Male connector, 8-pin
<b>Supply voltage</b>	7 V DC ... 12 V DC
<b>Warm-up time voltage ramp</b>	Max. 180 ms <sup>1)</sup>
<b>Recommended supply voltage</b>	11 V DC
<b>Current consumption</b>	≤ 150 mA <sup>2)</sup>

<sup>1)</sup> Duration of voltage ramp between 0 and 7.0 V.

<sup>2)</sup> At 7 V DC and without load.

## Mechanics

<b>Shaft version</b>	Through hollow shaft
<b>Dimensions</b>	See dimensional drawing
<b>Weight</b>	≤ 0.21 kg
<b>Moment of inertia of the rotor</b>	280 gcm <sup>2</sup>
<b>Operating speed</b>	6,000 min <sup>-1</sup> , up to which the absolute position can be reliably produced
<b>Angular acceleration</b>	≤ 50,000 rad/s <sup>2</sup>
<b>Permissible radial shaft movement</b>	± 0.15 mm
<b>Permissible axial shaft movement</b>	± 0.4 mm
<b>Permissible movement static</b>	± 0.3 mm
<b>Permissible movement dynamic</b>	± 0.1 mm

## Ambient data

<b>Operating temperature range</b>	-30 °C ... +115 °C
<b>Storage temperature range</b>	-40 °C ... +125 °C, without package
<b>Relative humidity/condensation</b>	85 %, Condensation not permitted <sup>1)</sup>
<b>Resistance to shocks</b>	100 g, 10 ms (according to EN 60068-2-27) <sup>2)</sup>
<b>Frequency range of resistance to vibrations</b>	30 g, 10 Hz ... 2,000 Hz (EN 60068-2-6) <sup>1)</sup>
<b>EMC</b>	According to EN 61000-6-2 and EN 61000-6-4 (Class A) <sup>3)</sup>
<b>Enclosure rating</b>	IP40, with mating connector inserted and closed cover (IEC 60529)

<sup>1)</sup> More information can be found in the white paper (DE: 8021543/EN: 8021544).

<sup>2)</sup> Every encoder has been tested with a half-sine-shaped shock.

<sup>3)</sup> The EMC according to the standards quoted is achieved when the motor feedback system is mounted in an electrically conductive housing, which is connected to the central earthing point of the motor controller via a cable screen. If other shielding concepts are used, users must perform their own tests.

## Certificates

<b>EU declaration of conformity</b>	✓
<b>UK declaration of conformity</b>	✓
<b>ACMA declaration of conformity</b>	✓
<b>Moroccan declaration of conformity</b>	✓
<b>China-RoHS</b>	✓
<b>Information according to Art. 3 of Data Act (Regulation EU 2023/2854)</b>	✓

## Classifications

<b>ECLASS 5.0</b>	27270590
-------------------	----------

<b>ECLASS 5.1.4</b>	27270590
<b>ECLASS 6.0</b>	27270590
<b>ECLASS 6.2</b>	27270590
<b>ECLASS 7.0</b>	27270590
<b>ECLASS 8.0</b>	27270590
<b>ECLASS 8.1</b>	27270590
<b>ECLASS 9.0</b>	27270590
<b>ECLASS 10.0</b>	27273805
<b>ECLASS 11.0</b>	27273901
<b>ECLASS 12.0</b>	27273901
<b>ETIM 5.0</b>	EC001486
<b>ETIM 6.0</b>	EC001486
<b>ETIM 7.0</b>	EC001486
<b>ETIM 8.0</b>	EC001486
<b>UNSPSC 16.0901</b>	41112113

### Dimensional drawing

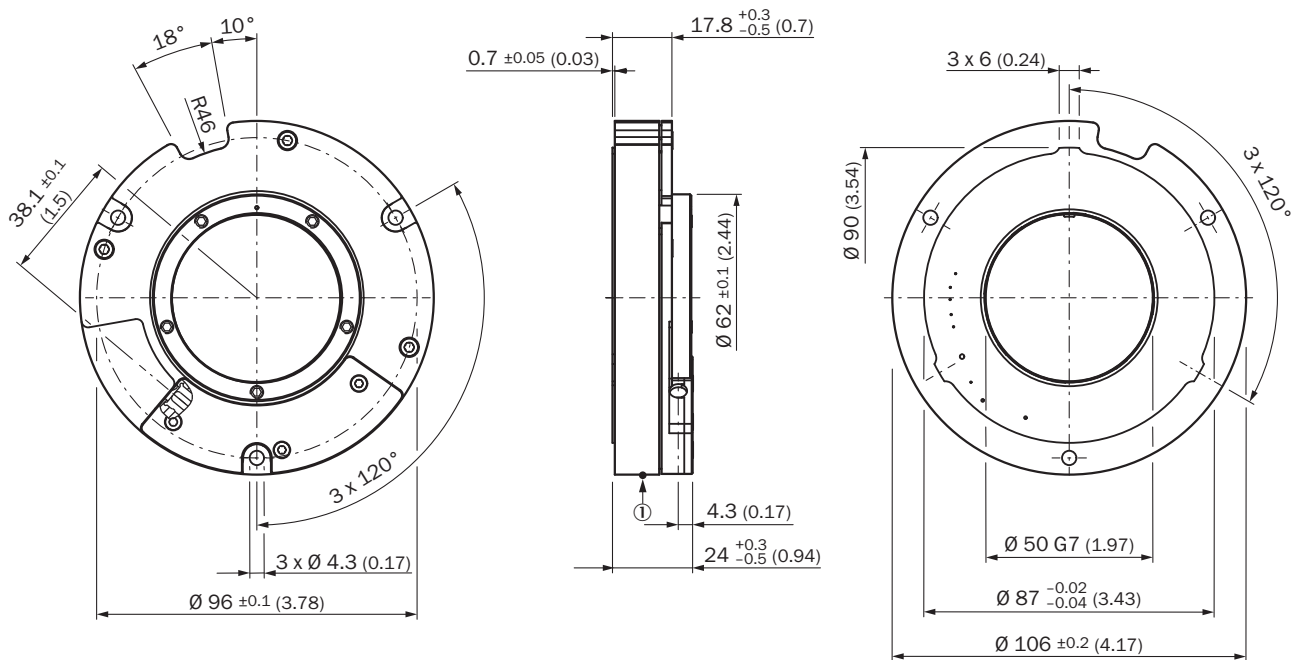

Dimensions in mm (inch)

① Measuring point for operating temperature

### Attachment specifications

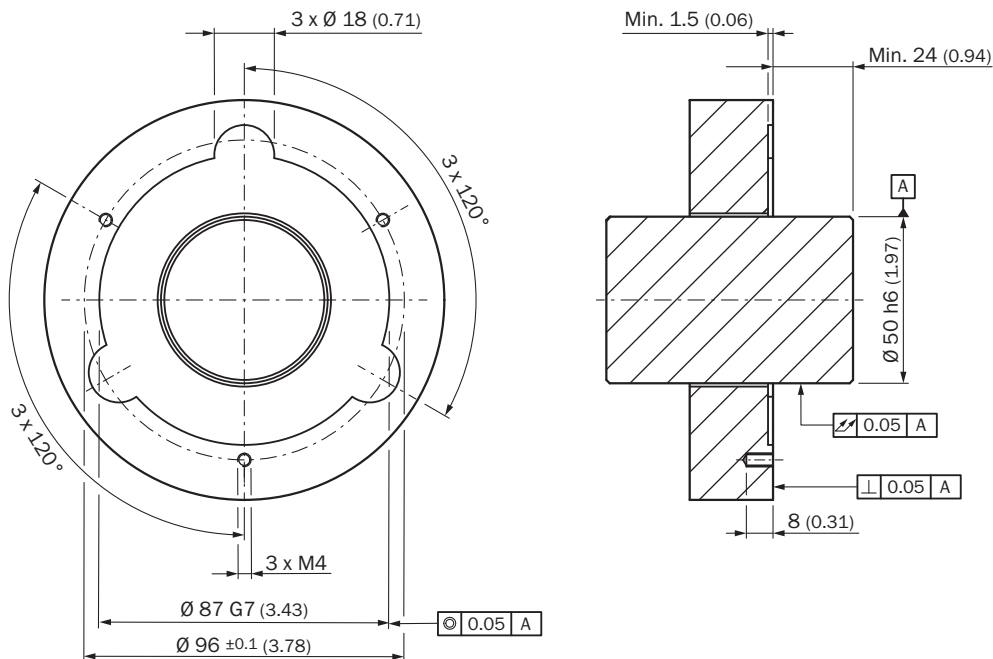

Read-out axial position: Negative number shows the movement of the robot away from the motor flange; positive number shows movement of the rotor towards the motor flange

### PIN assignment View of the plug-in face

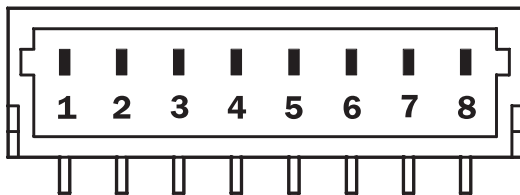

PIN	Signal	Wire colors (cable connection)	Explanation
1	$U_s$	Red	Supply voltage
2	+ SIN	White	Process data channel
3	REFSIN	Brown	Process data channel
4	+ COS	Pink	Process data channel
5	REFCOS	Black	Process data channel
6	GND	Blue	Ground connection
7	Data +	Gray or yellow	Parameter channel RS 485
8	Data -	Green or purple	Parameter channel RS 485

The GND connection (0 V) of the supply voltage is not connected to the housing

Operation note Supported resources for HIPERFACE<sup>®</sup>

Command byte	Function	Comments
42h	Read position	
43h	Set position	
44h	Read analog value	
		48h - Temperature in °C
		F0h - Temperature compatible to product families SCx °C * 2,048 - 40
46h	Read counter	
47h	Increment Counter	
49h	Delete counter	
4Ah	Read data	
4Bh	Store data	
4Ch	Determine status of a data field	
4Dh	Create data field	
4Eh	Determine available memory area	
4Fh	Change access code	
50h	Read encoder status	
52h	Read out type label	
53h	Encoder reset	
55h	Allocate encoder address	
56h	Read serial number and program version	
6Ch	Read Synchronization Offset	
6Dh	Axial Position	
Default interface settings can not be changed (e.g. baudrate, timeout or parity bit)		

## Operation note Overview of warnings and fault indications

	Status code	Description
Error type	00h	The encoder has not detected any faults
Initialization	01h	Incorrect alignment data
	02h	Incorrect internal angular offset
	03h	Data field partitioning table destroyed
	04h	Analog limit values not available
	05h	Internal I2C bus inoperative
	06h	Internal checksum error
Protocol	07h	Encoder reset occurred as a result of program monitoring
	09h	Parity error
	0Ah	Checksum of transmitted data is incorrect
	0Bh	Unknown command code
	0Ch	Number of transmitted data is incorrect
	0Dh	Transmitted command argument is not allowed
Data	0Eh	The selected data field may not be written to
	0Fh	Incorrect access code
	10h	Size of specified data field cannot be changed
	11h	Specified word address lies outside the data field
Position	12h	Access to non-existent data field
	01h	Analog signals outside specification
	1Fh	Speed too high, no position formation possible
	20h	Singleturn position unreliable
	21h	Multiturn position error
Other	22h	Multiturn position error
	23h	Multiturn position error
	1Ch	Value monitoring of the analog signals (process data)
	1Dh	Transmitter current critical or P2RAM-Error
	1Eh	Encoder temperature critical
	08h	Counter overflow

For more information on the interface see HIPERFACE® - description, part no. 8010701

## SICK AT A GLANCE

SICK is one of the leading manufacturers of intelligent sensors and sensor solutions for industrial applications. A unique range of products and services creates the perfect basis for controlling processes securely and efficiently, protecting individuals from accidents and preventing damage to the environment.

We have extensive experience in a wide range of industries and understand their processes and requirements. With intelligent sensors, we can deliver exactly what our customers need. In application centers in Europe, Asia and North America, system solutions are tested and optimized in accordance with customer specifications. All this makes us a reliable supplier and development partner.

Comprehensive services complete our offering: SICK LifeTime Services provide support throughout the machine life cycle and ensure safety and productivity.

For us, that is “Sensor Intelligence.”

## WORLDWIDE PRESENCE:

Contacts and other locations –[www.sick.com](http://www.sick.com)