

TR110-XAFR

Actuators for RFID safety switches

ACTUATORS

SICK
Sensor Intelligence.

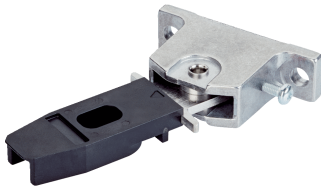

Ordering information

Type	part no.
TR110-XAFR	5338332

Other models and accessories → www.sick.com/Actuators_for_RFID_safety_switches



Detailed technical data

Features

Accessory group	Actuators for RFID safety switches
Description	Hinged actuators for doors with hinges on right
Suitable for	TR110 Lock
Items supplied	Including two safety screws M5

Certificates

EU declaration of conformity	✓
UK declaration of conformity	✓
ACMA declaration of conformity	✓
China-RoHS	✓

Classifications

ECLASS 5.0	27279290
ECLASS 5.1.4	27279290
ECLASS 6.0	27279222
ECLASS 6.2	27279222
ECLASS 7.0	27279222
ECLASS 8.0	27279222
ECLASS 8.1	27279222
ECLASS 9.0	27270612
ECLASS 10.0	27270612
ECLASS 11.0	27270612
ECLASS 12.0	27270612
ETIM 5.0	EC002594
ETIM 6.0	EC002594
ETIM 7.0	EC002594
ETIM 8.0	EC002594
UNSPSC 16.0901	31251501

Dimensional drawing

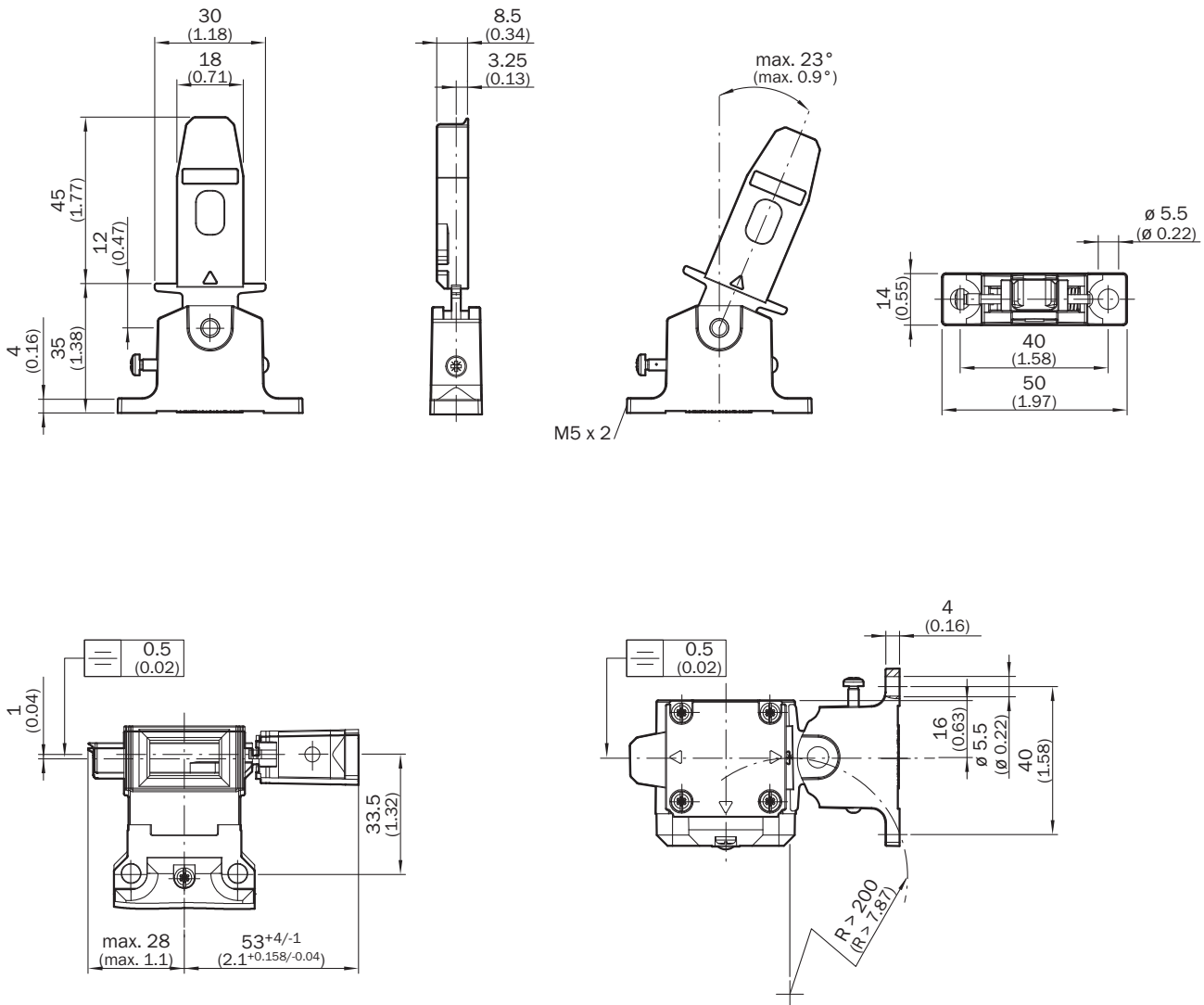

Dimensions in mm (inch)

SICK AT A GLANCE

SICK is one of the leading manufacturers of intelligent sensors and sensor solutions for industrial applications. A unique range of products and services creates the perfect basis for controlling processes securely and efficiently, protecting individuals from accidents and preventing damage to the environment.

We have extensive experience in a wide range of industries and understand their processes and requirements. With intelligent sensors, we can deliver exactly what our customers need. In application centers in Europe, Asia and North America, system solutions are tested and optimized in accordance with customer specifications. All this makes us a reliable supplier and development partner.

Comprehensive services complete our offering: SICK LifeTime Services provide support throughout the machine life cycle and ensure safety and productivity.

For us, that is “Sensor Intelligence.”

WORLDWIDE PRESENCE:

Contacts and other locations –www.sick.com